



INSTRUCTION MANUAL FOR OIL BURNER MODELS

X400-1 – Low voltage – 12v dc – Brushed motor



Contents

Technical specifications

Technical data	3
Working field	3
Dimensions	4
Head and electrode settings	5
Components.....	6

Burner installation

Mounting onto the appliance	7
Electrical connection.....	7
Fuel supply	7
Air supply	7

Burner operation

Before start-up.....	8
Start-up procedure	8
Normal operating mode	9

Burner servicing

Combustion head.....	9
Oil pump	11
Oil supply line tables.....	13
Nozzle table	14
Fault finding table	15
Commissioning report sheet.....	17
Burner service record	18
Notes.....	19

Important note

The contents of the manual must be read and followed prior to the fitting and commissioning of the burner.

Any work on this burner must be carried out by a suitably qualified, and experienced, engineer.

Any electrical or fuel supply must be isolated before any work is carried out.

The installation must be carried out in accordance with current Electrical Regulations and all relevant Building Regulations.

Technical specifications

Technical Data

Burner output	Min kW	14
	Max kW	26
Fuel flow rate	Min Kg/hr	1.2
	Max Kg/hr	2.2
Fuel	Kerosene	Max viscosity 5.5 cst @ 20° C
	Gas oil	
Electrical supply	Input	12v d.c.
	Motor	12v d.c. 50 watt
	Ignition unit	24v d.c.
	Start current	20 amps
	Run current	11.5 amps
Weight		8.1 kg
Mode		On-off

Working field

X400-1N

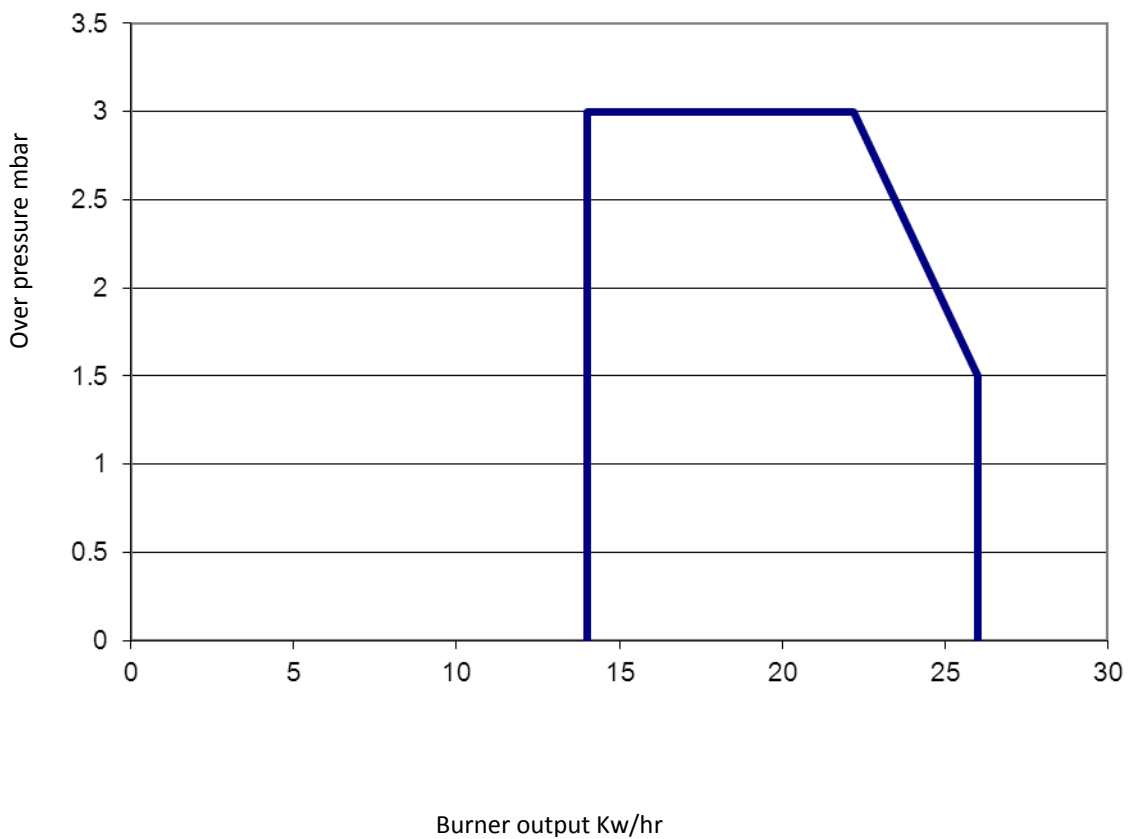

Technical specifications

Dimensions (mm)

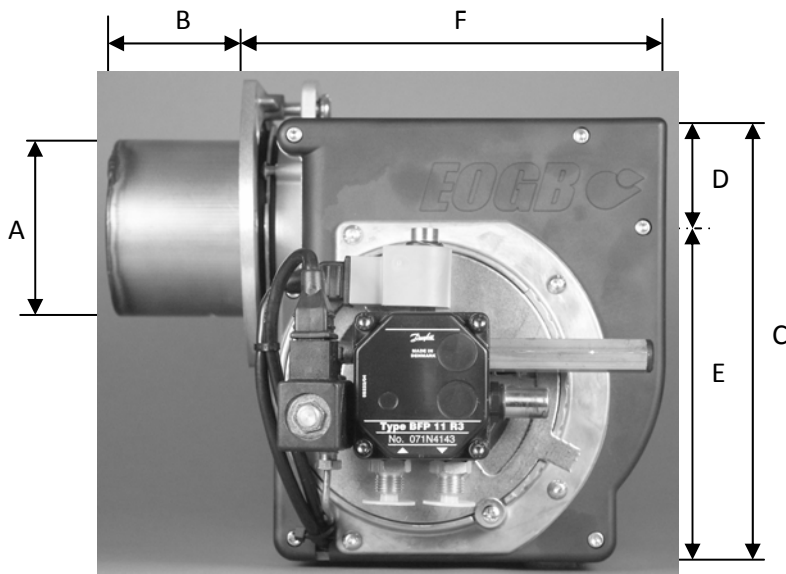

A	89
B	73
C	231
D	50
E	161
F	194

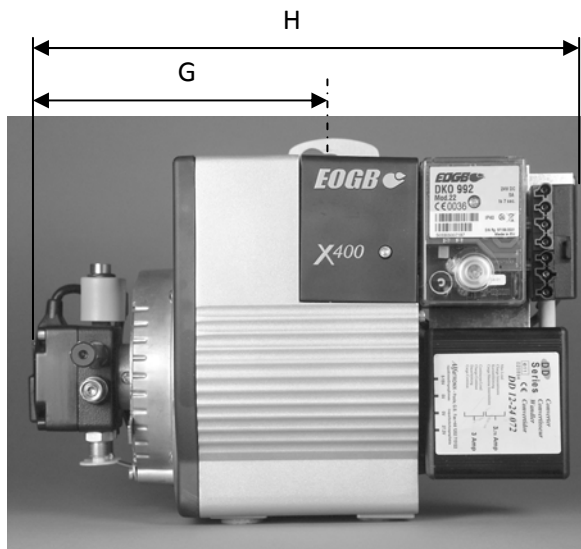

G	195
H	345

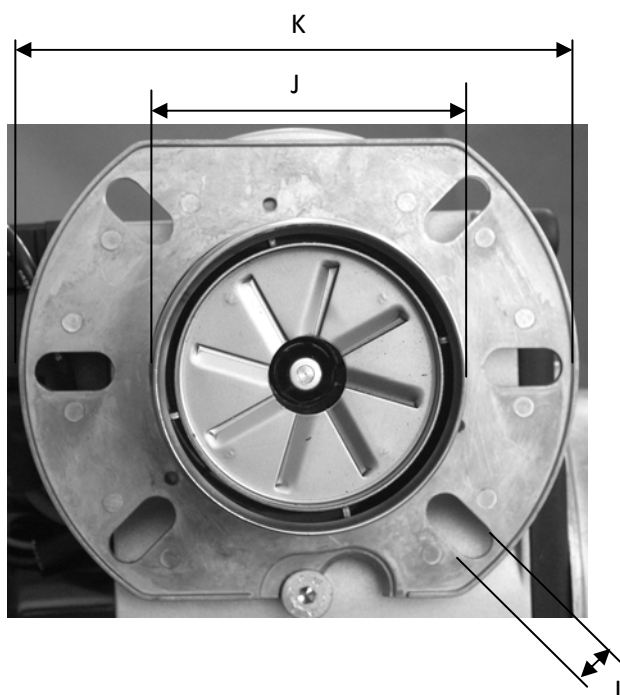

J	90
K	125-150
L	10

Technical specifications

Head and electrode settings (mm)

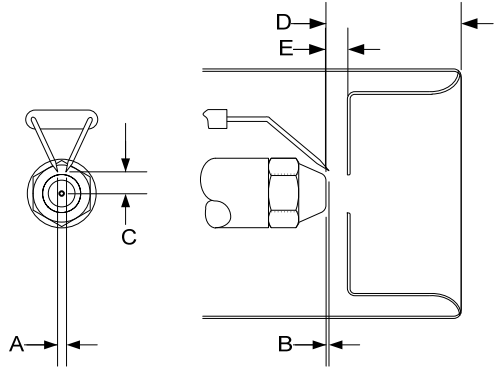

Model					
	A	B	C	D	E
X400-1	3.5	-1	9	43	4

Technical specifications

Components

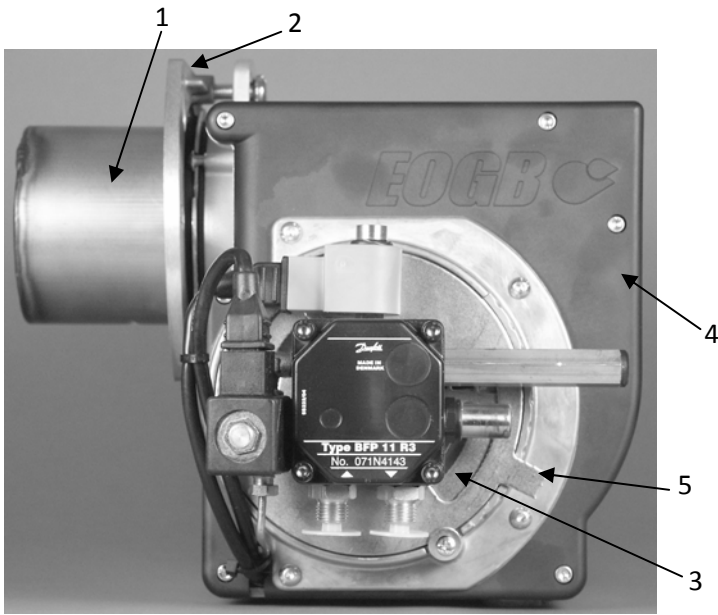

1	Blast tube
2	Mounting flange
3	Air intake
4	Fanhouse
5	Air adjuster

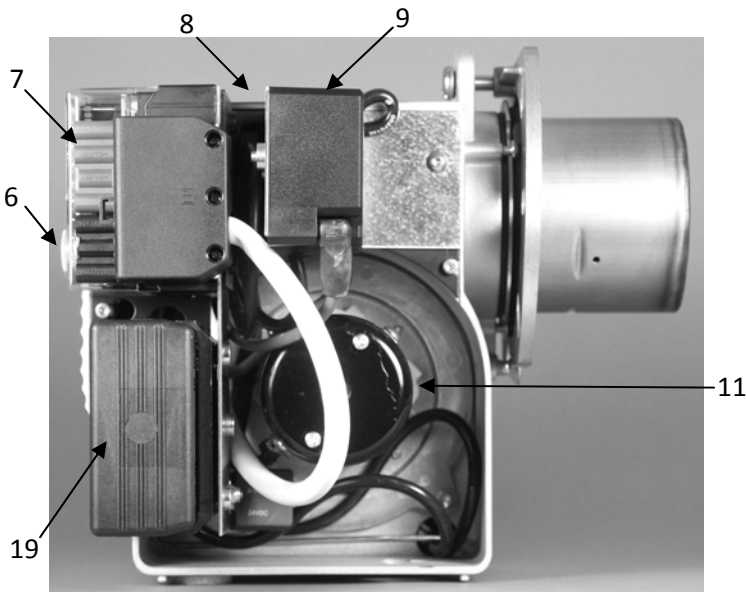

6	Lockout reset button
7	Control box
8	Photocell (hidden)
9	Ignition unit
11	Motor
19	24v – 12v converter

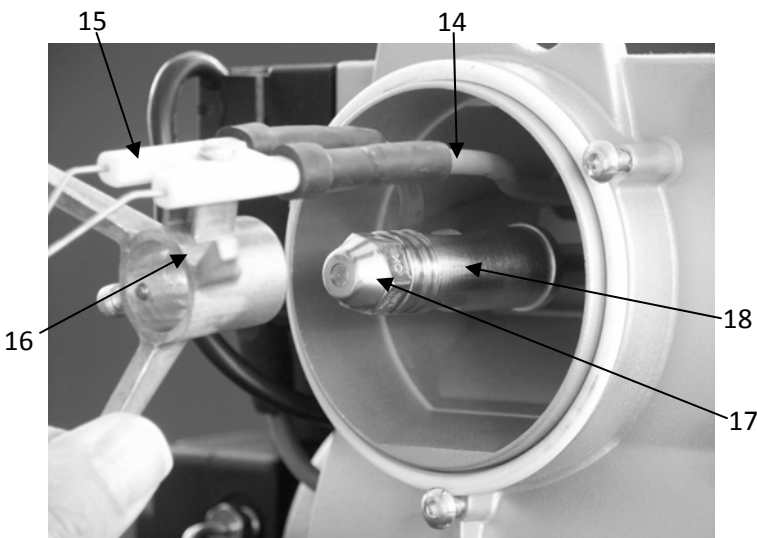

14	H.T. leads
15	Ignition electrodes
16	Electrode holder
17	Nozzle
18	Nozzle assembly

Burner installation

Mounting onto the appliance

The burner is mounted onto the appliance by means of a removable 6-bolt flange.

The gasket needs to be put in place before the flange is fixed onto the appliance. The burner tube is then inserted through the centre hole after fitting the O-ring over the the blast tube.

With the burner rotated a few degrees clockwise the flange bolts will pass through the locating holes. When the burner is twisted into position the top bolt can then be tightened to secure the burner. If necessary the lower screw can be adjusted to give a more secure fixing.

If required the burner can be mounted in any position. It is important though to ensure that the solenoid valve on the oil pump is not inclined below horizontal.

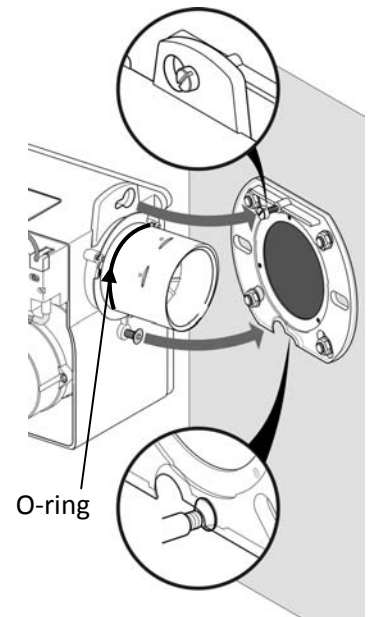

Electrical connection

The electrical connections to this burner must be carried out by a suitably qualified engineer.

All Electrical connections to the burner must be carried out in accordance with all current applicable IEE Wiring Regulations.

All connections should be made according to the wiring diagram shown on the supplementary page.

The burner is fitted with a 7-pin socket pre-wired into the burner.

Fuel supply

The burner is usually supplied for two-pipe operation but if required can be converted for a one-pipe gravity system (details elsewhere in this manual). When used in conjunction with a gravity feed supply the inlet pressure to the pump **MUST NOT** exceed 2 bar.

When using a two-pipe system the return line has to be fed back into the tank. Alternatively, a de-aeration device could be incorporated for ease of installation.

Oil lines must be completely air-tight and constructed in accordance with current standards.

The final connection to the oil pump must be made with the flexible oil line provided.

Air supply

Combustion air and ventilation requirements are detailed in BS5410:Part1. It requires that combustion air must be provided through purpose-made non-closeable openings, having a total free area of 550mm² per kW of the appliance maximum output rating above 5kW.

Burner operation

Before start-up

Check that the correct nozzle is fitted. Reference should be made to the instructions of the appliance manufacturers.

If the burner is firing Kerosene the nozzle must be sized for a maximum pump pressure of 10 bar (145 psi). If Gas Oil is being used then a smaller nozzle must be selected to allow a pump pressure of approx 14 bar (200 psi). This is necessary to give better fuel atomisation and therefore better combustion.

Fit a pressure gauge to the oil pump (as shown in the diagram below).

Start-up procedure

Close the main switch and the thermostats to allow the burner to start up.

The burner motor and ignition transformer are both powered during the pre-purge period.

During pre-purge the oil pressure can be set, as the pressure will register before the solenoid valve is opened (see diagram).

If necessary the oil supply can be de-aerated from the pump through the pressure gauge manifold.

During this pre-purge period checks are made for 'stray-light' onto the photocell and the integrity of the solenoid coil of the pump. If 'stray-light' is detected, or if the coil is faulty, then the coil will not receive full voltage and therefore will not release any fuel.

If checks are ok then power is fed to the solenoid coil and the valve will open.

Fuel is then released to the nozzle.
The spark will ignite the fuel spray.

If a flame is formed this will be detected by the photocell and the control box will turn off the ignition and assume normal run mode.

If a flame is not formed, or detected, then the control box will go to a lockout condition and the indicator lamp on the control box will be illuminated. The control box will need to be reset to enable the burner to re-attempt a start up.

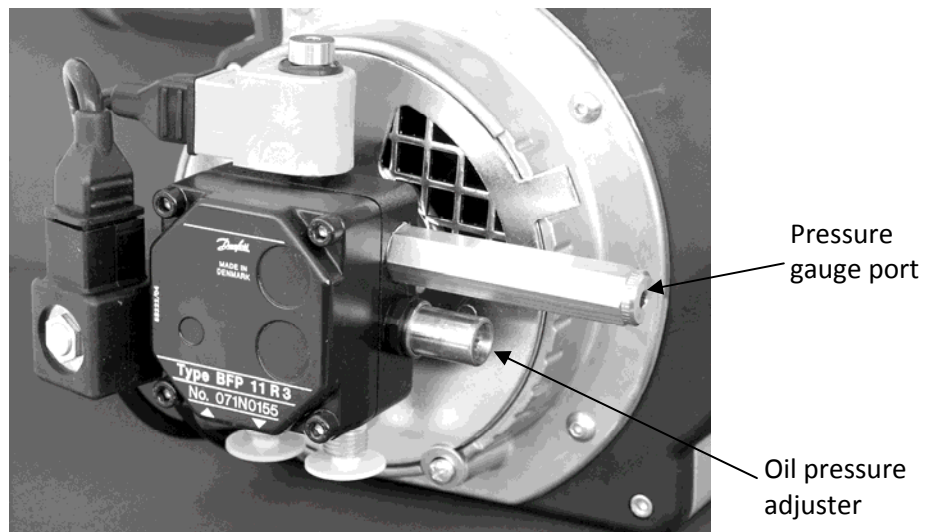

Normal operating mode

Check the oil pressure on the gauge and adjust if necessary for the required burner output.

From a suitable test point on the boiler, or in the flue, a smoke reading should be taken to ensure clean smoke-free combustion.

With the aid of a flue gas analyser, and by making adjustments to the air adjuster, the combustion can be set for maximum efficiency (see diagram).

The air control rotates and is locked in place by the air damper locking screw.

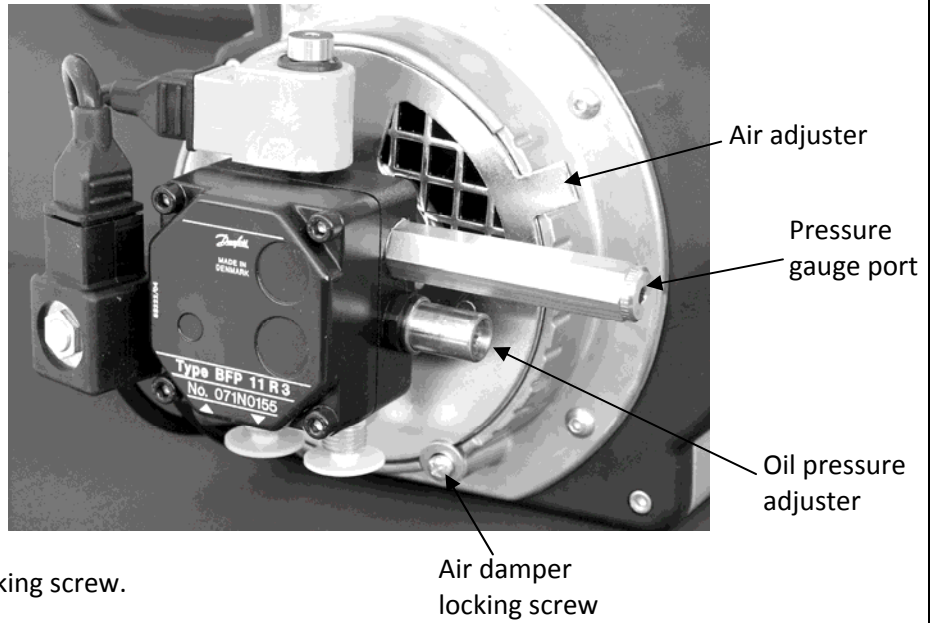

A CO₂ level of around 11.0% - 12.0% should be achievable.

If at any point during normal operating mode the photocell loses sight of the flame the control box will attempt to re-establish the flame. The oil valve will close and the ignition transformer will be powered. A pre-purge will be carried out before the valve is re-opened and the fuel is released. If successful the burner will continue in operating mode; if not the control box will go into lockout mode.

After commissioning a safety check must be carried out to ensure the correct operation of the flame detection.

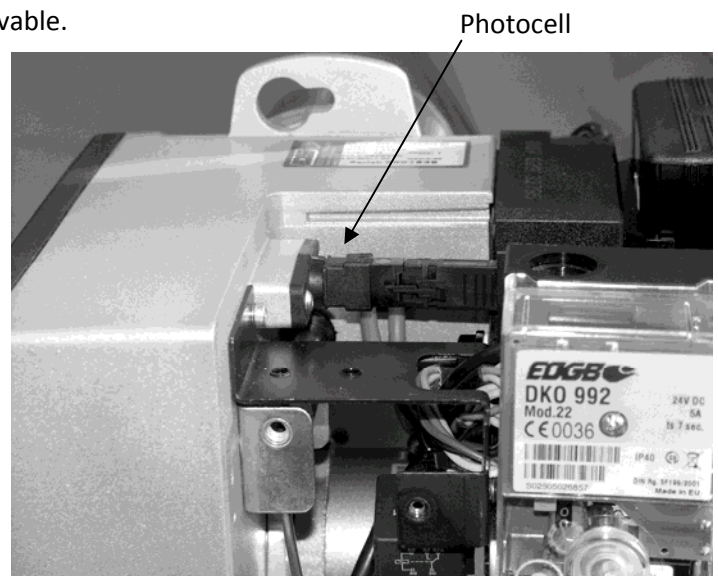

During normal operation the photocell is to be removed and either covered with a clean rag to prevent any light from being sensed, or for the cell to be unplugged. As soon as this happens the burner will attempt to re-establish the flame

IMPORTANT: The photocell side opening must be pointing at the flame for reliable operation.

Burner servicing

Combustion head

For ease of servicing and access to the burner components the burner has, on the bottom face, a keyhole cut-out. This allows the burner to be hung from the mounting flange in a more convenient position.

After loosening the fixing bolt the burner can be extracted from the flange, turned around and then the keyhole can be located onto the bolt.

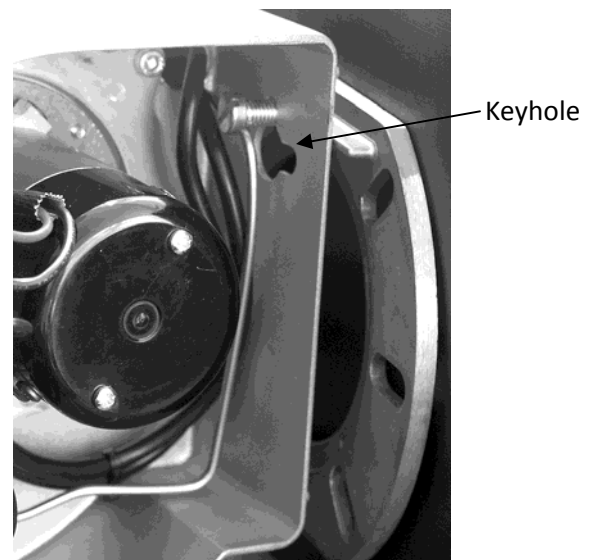

The burner service requires that all of the components are cleaned and checked for correct operation, or signs of damage. A check must be carried out on all safety devices i.e. photocell, solenoid valves, etc. The nozzle should be replaced every 12 months, or sooner if worn or dirty. Filters and fuel lines must be inspected and replaced if necessary.

Here are a series of diagrams showing the removal of the combustion head components from the burner. This gives access for the nozzle to be replaced and the electrodes to be inspected.

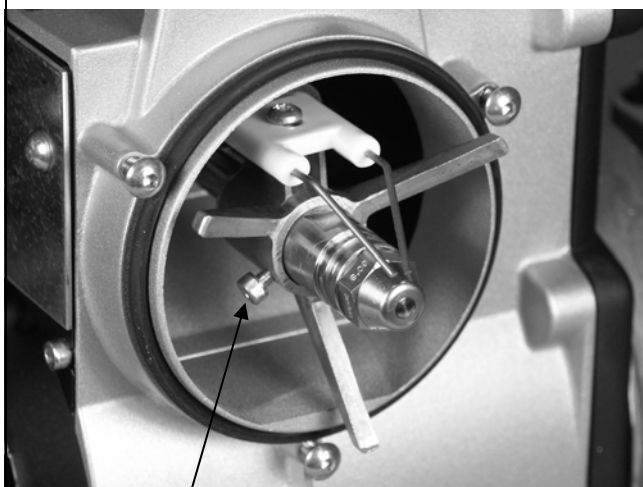
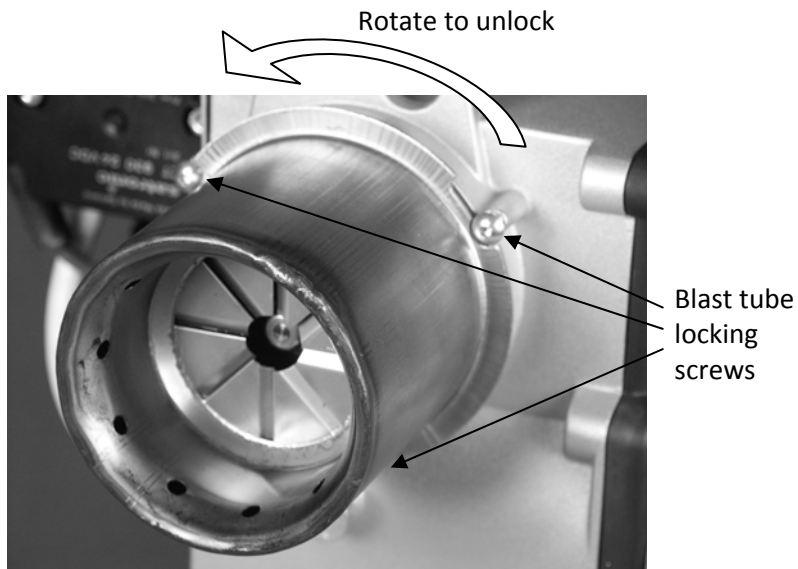

Electrode assembly locking screw

As shown the electrode assembly is to be removed from the nozzle holder before the nozzle is replaced. This will prevent any accidental damage.

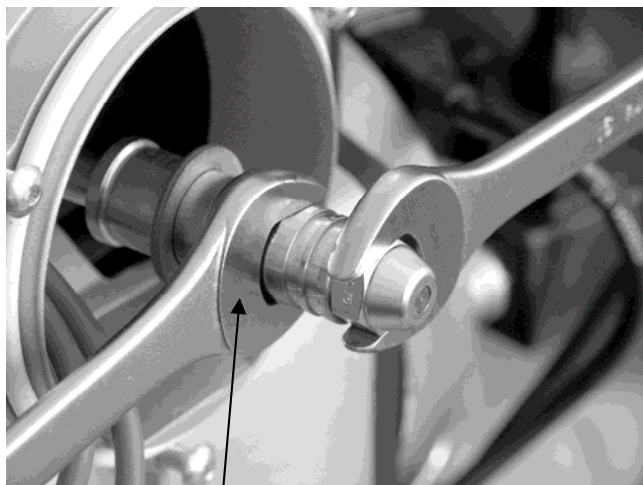
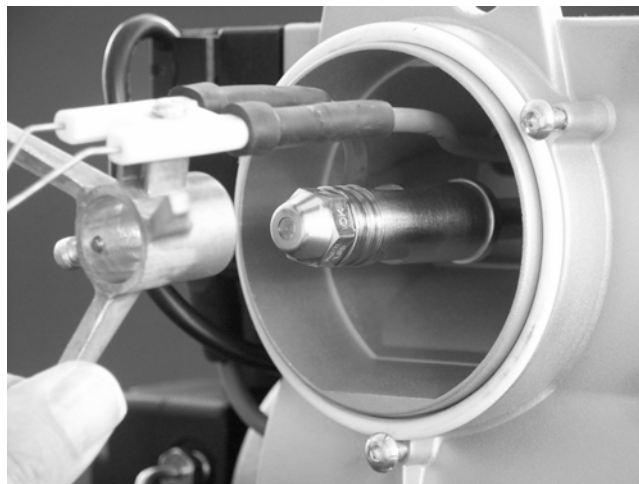

Prevent inner oil pipe from rotating

It is important that the nozzle holder is prevented from rotating by use of a second spanner while unscrewing the nozzle

Once the burner has been re-fitted a smoke check and combustion analysis must be carried out. Once the burner has been commissioned on the appliance and all settings are correct the figures should then be recorded.

The burner and all other related equipment must be left in a safe and reliable working order.

Fuel pump type Danfoss BFP11 R3

Technical data

Oil Viscosity range: 1.3 – 12.0 cSt

Pressure range: 7 – 15 bar

Oil temperature: -10 - +70°C

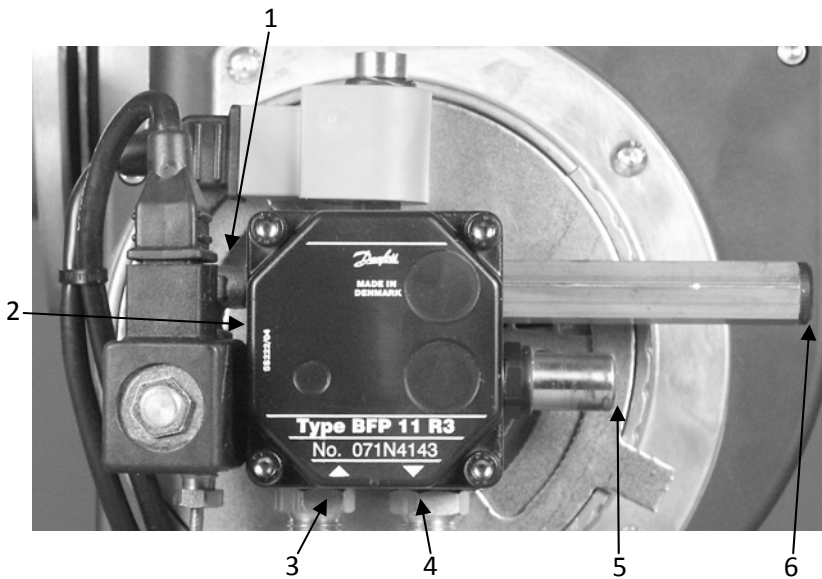

1 - Nozzle port 1/8"

2 - Vacuum gauge port 1/8"

3 - Suction line port 1/4"

4 - Return line port 1/4"

5 - Pressure adjustment (4mm allen key)

6 - Pressure gauge port 1/8"

1 or 2 pipe operation

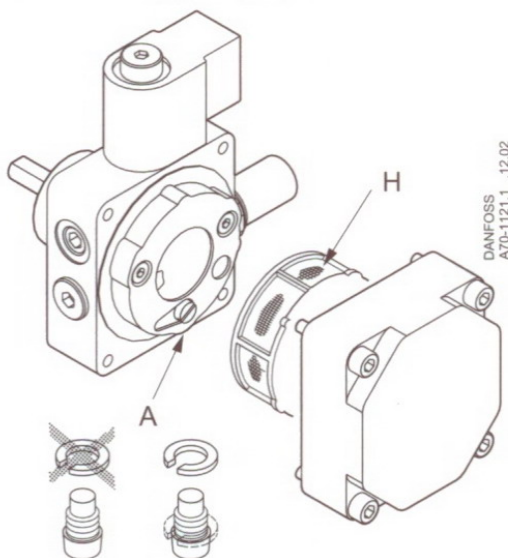

H – Filter

A – Bypass washer

The fuel filter and bypass washer are located within the pump housing. By removing the 4 fixing screws the housing can be removed allowing access.

The bypass washer is located under the bottom of the 3 internal screws.

In case of one-pipe operation the horseshoe-shaped copper washer will be mounted under the screw head, and in case of two-pipe operation, the horseshoe-shaped copper washer will be removed.

2-pipe operation:
Screw (A) without
bypass washer

1-pipe operation:
Bypass washer
fitted on screw (A)

Fuel pump type Danfoss BFP...

Function

As the oil pump turns it draws oil from the suction line connection **S**, through the filter **H** and into the suction side of the gear set **C**. Any suction generated before the gear set can be measured with an appropriate vacuum gauge at connection **V**.

The gear set then pumps the oil through and puts it under pressure. The pressure is measured at connection **P1**. No oil will be released to the nozzle port **E** until the normally closed solenoid valve **NC** is opened.

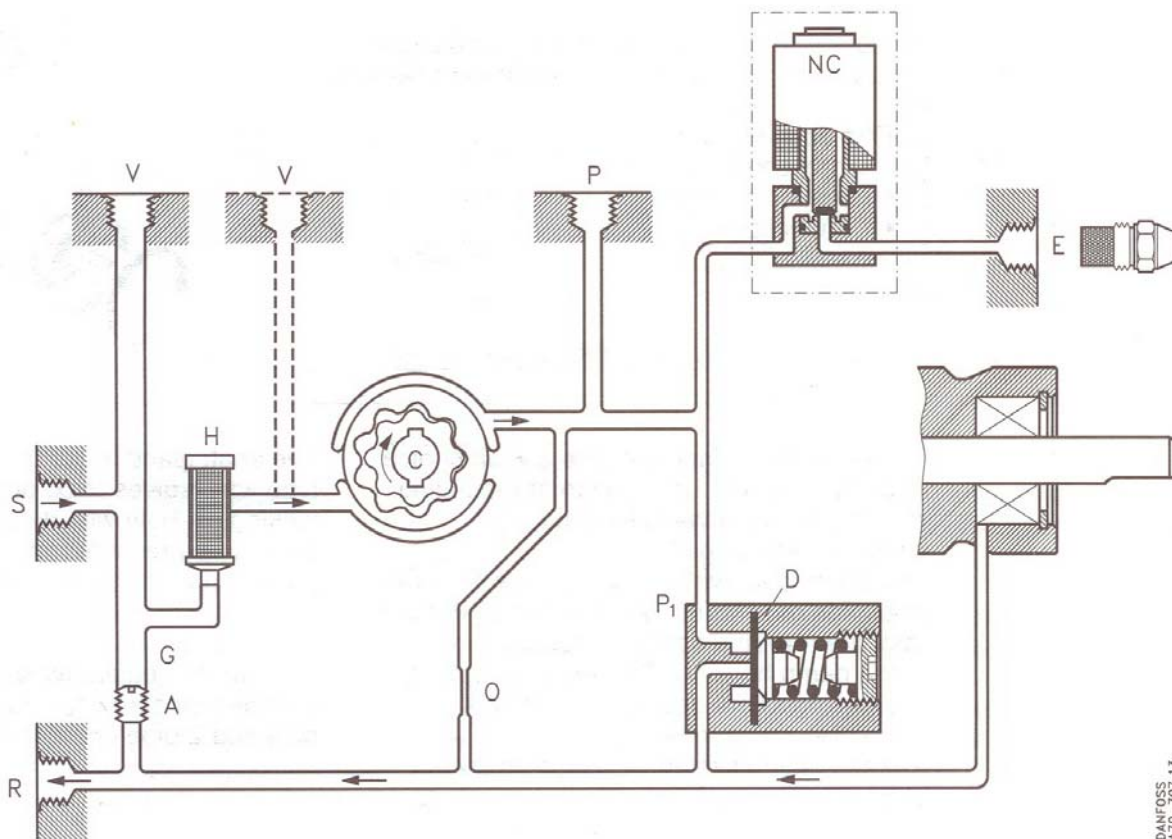

The pressure is controlled and kept constant by means of the diaphragm **D** behind the pressure regulator **P₁**. The pressure regulator **P₁** distributes the oil quantity supplied by the gear set between the nozzle port **E** and the return side of the pump **R**.

The oil quantity supplied is determined by the setting of the pressure regulator **P₁** and the size of the oil nozzle in the nozzle line **E**.

When the opening pressure has been reached, the passage to the return side of **P₁** opens. The diaphragm and the spring keep the pump pressure constant at the set value.

When used in a one-pipe installation connection **R** is closed and **A** must be removed to allow internal recirculation of the fuel. If **A** is not opened then damage to the pump seals will occur.

If a two-pipe system is required then a return line must be fitted into connection **R** and **A** must be fitted to divert the recirculating oil out through the return line.

Oil supply line tables

One-pipe system

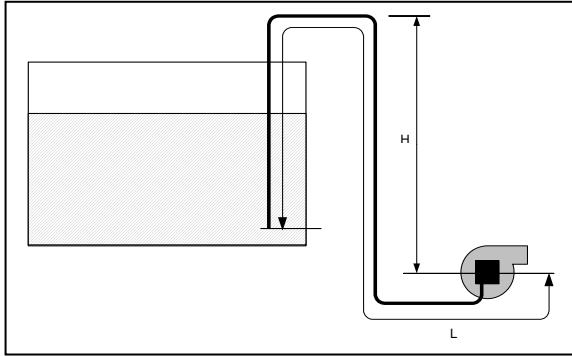

Kerosene 2.15 mm²s (cSt)

H m	Ø4 mm	Ø5 mm	Ø6 mm	Ø5 mm	Ø6 mm	Ø8 mm
4.0	66	100	100	33	80	100
3.5	57	100	100	29	70	100
3.0	49	100	100	25	60	100
2.5	41	100	100	20	50	100
2.0	33	80	100	16	40	83
1.5	25	60	100	12	30	62
1.0	16	40	83	8	20	41
0.5	8	20	41	4	10	20
Nozzle capacity	5.0 kg/h			10.0 kg/h		

Gas oil 6.00 mm²s (cSt)

H m	Ø4 mm	Ø5 mm	Ø6 mm	Ø5 mm	Ø6 mm	Ø8 mm
4.0	26	60	100	31	62	100
3.5	22	51	100	27	55	100
3.0	19	44	94	23	47	100
2.5	16	37	78	20	39	100
2.0	13	30	62	16	31	98
1.5	10	22	47	12	23	74
1.0	6	15	31	8	15	49
0.5	3	7	15	4	7	24
Nozzle capacity	5.0 kg/h			10.0 kg/h		

Two-pipe system

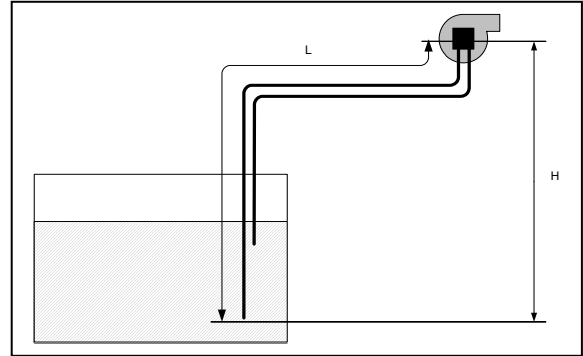

Kerosene 2.15mm²s (cSt)

H m	Ø6 mm	Ø8 mm	Ø10 mm
-0.0	54	100	100
-0.5	48	100	100
-1.0	42	100	100
-1.5	36	100	100
-2.0	30	94	100
-2.5	24	75	100
-3.0	18	55	100
-3.5	11	36	88
-4.0	5	16	40

Gas oil 6.00 mm²s (cSt)

H m	Ø6 mm	Ø8 mm	Ø10 mm
-0.0	17	53	100
-0.5	15	47	100
-1.0	13	41	99
-1.5	11	34	84
-2.0	9	28	68
-2.5	7	22	53
-3.0	5	15	37
-3.5	—	9	22
-4.0	—	—	6

These tables are shown merely as guidance for the suitability of the oil supply line installation. The typical pipe system used for the calculations comprises – 1 x check valve, 1 x cut off valve, 1 x in-line filter and 4 x 90° elbows

Nozzle table

Pump Pressure - bar

Gph	8			9			10			11			12			13			14			15		
	kg/h	kW	Mcal/h	kg/h	kW	Mcal/h	kg/h	kW	Mcal/h	kg/h	kW	Mcal/h	kg/h	kW	Mcal/h	kg/h	kW	Mcal/h	kg/h	kW	Mcal/h	kg/h	kW	Mcal/h
0.40	1.33	16	13	1.41	17	14	1.49	18	15	1.56	18	16	1.63	19	17	1.70	20	17	1.76	21	18	1.82	21	18
0.50	1.66	20	17	1.76	21	18	1.86	22	19	1.95	23	20	2.04	24	21	2.12	25	22	2.20	26	22	2.28	27	23
0.60	2.00	24	20	2.12	25	22	2.23	26	23	2.34	28	24	2.45	29	25	2.55	30	26	2.64	31	27	2.73	32	28
0.65	2.16	26	22	2.29	27	23	2.42	29	25	2.54	30	26	2.65	31	27	2.75	33	28	2.86	34	29	2.96	35	30
0.75	2.49	29	25	2.65	31	27	2.79	33	28	2.93	35	30	3.08	36	31	3.18	38	32	3.30	39	34	3.42	40	35
0.85	2.83	33	29	3.00	36	31	3.16	37	32	3.32	39	34	3.47	41	35	3.61	43	37	3.74	44	38	3.87	46	39
1.00	3.33	39	34	3.53	42	36	3.72	44	38	3.90	46	40	4.08	48	42	4.24	50	43	4.40	52	45	4.56	54	46
1.10	3.66	43	37	3.88	46	39	4.09	48	42	4.29	51	44	4.48	53	46	4.67	55	48	4.84	57	49	5.01	59	51
1.20	3.99	47	41	4.24	50	43	4.47	53	46	4.68	55	48	4.89	58	50	5.09	60	52	5.29	63	54	5.47	65	56
1.25	4.16	49	42	4.40	52	45	4.65	55	47	4.88	58	50	5.10	60	52	5.30	63	54	5.51	65	56	5.70	68	58
1.35	4.49	53	46	4.76	56	48	5.02	59	51	5.27	62	54	5.50	65	56	5.73	68	58	5.95	70	61	6.15	73	63
1.50	4.98	59	51	5.29	63	54	5.58	66	57	5.85	69	60	6.11	72	62	6.36	75	65	6.60	78	67	6.83	81	70
1.65	5.49	65	56	5.82	69	59	6.14	73	63	6.44	76	66	6.73	80	69	7.00	83	71	7.27	86	74	7.52	89	77
1.75	5.82	69	59	6.18	73	63	6.51	77	66	6.83	81	70	7.14	85	73	7.42	88	76	7.71	91	79	7.97	94	81
2.00	6.65	79	68	7.06	84	72	7.45	88	76	7.81	93	80	8.18	97	83	8.49	101	86	8.81	104	90	9.12	108	93
2.25	7.49	89	76	7.94	94	81	8.38	99	85	8.78	104	89	9.18	109	94	9.55	113	97	9.91	117	101	10.26	122	105
2.50	8.32	99	85	8.82	105	90	9.31	110	95	9.76	116	99	10.19	121	104	10.61	126	108	11.01	130	112	11.39	135	116
2.75	9.15	108	93	9.71	115	99	10.24	121	104	10.73	127	109	11.21	133	114	11.67	138	119	12.11	144	123	12.53	148	128
3.00	9.98	118	102	10.59	126	108	11.16	132	114	11.71	139	119	12.23	145	125	12.73	151	130	13.21	157	135	13.67	162	139
3.50	11.65	138	119	12.35	146	126	13.03	154	133	13.66	162	139	14.27	169	145	14.85	176	151	15.42	183	157	15.95	189	163
4.00	13.31	158	136	14.12	167	144	14.89	176	152	15.62	185	159	16.31	193	166	16.97	201	173	17.62	209	180	18.23	216	186
4.50	14.97	177	153	15.88	188	162	16.75	198	171	17.57	208	179	18.35	217	187	19.10	226	195	19.82	235	202	20.51	243	209
5.00	16.64	197	170	17.65	209	180	18.62	221	190	19.52	231	199	20.39	242	208	21.22	251	216	22.03	261	225	22.79	270	232
5.50	18.30	217	187	19.42	230	198	20.48	243	209	21.47	255	219	22.43	266	229	23.34	277	238	24.23	287	247	25.07	297	256
6.00	19.97	237	204	21.18	251	216	22.34	265	228	23.42	278	239	24.47	290	249	25.46	302	260	26.43	313	269	27.49	326	280
6.50	21.63	256	220	22.94	272	234	24.20	287	247	25.37	301	259	26.51	314	270	27.58	327	281	28.63	339	292	29.63	351	302
7.00	23.29	276	237	24.71	293	252	26.06	309	266	27.33	324	279	28.55	338	291	29.70	353	303	30.84	366	314	31.91	378	325
7.50	24.96	296	254	26.47	314	270	27.92	331	285	29.29	347	298	30.59	363	312	31.83	377	324	33.04	392	337	34.19	405	349
8.00	26.62	316	271	28.24	335	288	29.79	353	304	31.23	370	318	32.63	387	333	33.95	403	346	35.25	418	359	36.47	432	372
8.50	28.28	335	288	30.00	356	306	31.65	375	323	33.18	393	338	34.66	411	353	36.07	428	368	37.45	444	382	38.74	459	395
9.00	29.95	355	305	31.77	377	324	33.59	398	342	35.14	417	358	36.71	435	374	38.19	453	389	39.65	470	404	41.02	486	418

Nozzle capacity - usg/h

Figures shown are for an oil of viscosity 4.4mm²/s (cSt), Density 830 kg/cm³

Fault finding

Below is a list of some scenarios that may lead to a failure causing the burner to go into lockout mode. There are also some relevant tests and solutions to hopefully overcome any problem that may occur.

Push the reset button to re-start the burner. If the burner then functions correctly the control has simply responded to a temporary fault. If the burner still fails then a further investigation will be required to correct any fault.

Fault	Probable cause	Useful Test	Solution
The burner will not start	1) Lack of voltage.	If there is significantly less than 24v dc on terminal 9 then the control box will lock out. If there is no voltage then there is an external fault.	Replace control box if 24v dc present. Investigate reason for low voltage Check any thermostats, switches, fuses, etc to trace fault.
The burner starts but no flame is present and the burner goes to lockout	No fuel to burner. No fuel to the nozzle. No voltage to solenoid coil Voltage to coil but not energizing. Coil energized but no oil at pump outlet. Oil at pump outlet but none through the nozzle. No spark	Check if there is oil present at the pump inlet Cover photocell. If burner fires up ok then photocell must be detecting a light source during pre-purge. If there is still no flame disconnect photocell. If now ok then cell must be faulty. 3) Check electrodes, HT leads and voltage to igniter. If all ok then igniter is faulty.	1) Check fuel tank, valves, etc for problems. 2) Identify source, spark, etc and remedy. Replace photocell Replace coil. Check valve opening. Replace if necessary. Replace nozzle, or check line for blockage. Replace igniter.
The burner starts, a flame is established but the burner goes to lockout	Check burner wiring. Flame recognition.	Expose photocell to good ambient (or torch) light. If the problem disappears then the problem is with the flame picture If the problem does not disappear then the photocell must be at fault	Remedy wiring connections. Reset combustion. b) Replace photocell.

Flame is pulsating	Faulty or dirty nozzle Excessive flue draught.	2) Measure draught.	Replace nozzle. Reset combustion or adjust draught stabilizer (if fitted).
Smoking Flame	Faulty nozzle. Combustion not set correctly. Insufficient air. Fuel pressure too low	Check combustion. 3) Check combustion. 4) Check fuel pressure.	Replace nozzle. Reset combustion Increase air setting. Check ventilation. Increase fuel pressure.
Burner keeps bringing ignition back on	Flame recognition. Low sulphur fuel.	Expose photocell to good ambient (or torch) light. If the problem disappears then the problem is with the flame picture If the problem does not disappear then the photocell must be at fault As above.	Reset combustion. Replace photocell. 2) Reset combustion to give a higher CO ₂ level.

WARNING:

Do not keep the lockout reset button permanently pressed as this will overheat the ignition unit. Allow 2 minutes between reset attempts to allow sufficient cooling.

Please note: The information given above is provided to assist the engineer with any problems they may encounter. This is not a definitive list.

If further problems are encountered then please contact EOGB Energy Products Ltd for advice.

Technical helpline – Tel: 08703-899499

COMMISSIONING REPORT SHEET

Commissioning Engineer	
Address	
Date of Commissioning	
Site Address	

Appliance

Make			
Model		Serial No.	
Output	<i>kW</i>	Fuel	
Type of Flue			

Burner

Model		Nozzle Make	
Serial No.		Angle & Pattern	

Settings

CO ₂	%		Flue Draft	<i>mbar</i>	
CO	<i>ppm</i>		Air Setting	<i>No</i>	
O ₂	%		Head Setting	<i>No</i>	
Smoke	<i>No.</i>		Flue Gas Temp. Nett	°C	
Efficiency	%		Pump Pressure	<i>bar</i>	

Please note: This report sheet must be completed by the Commissioning Engineer and the book is to be left with the appliance.

Notes



EOGB Energy Products Ltd

5 Howard Road, Eaton Socon,
St Neots, Cambs, PE19 8ET
Telephone: 01480 477066
Facsimile: 01480 477022

Website: www.eogb.co.uk
E-mail: sales@eogb.co.uk

